

HI-TEMP



Item no. 11314 HT 75 - 75kW



- **Outer jacket of thermoplastic** - High quality and long service life.
- **Hot water coil made of acid-resistant stainless steel** - For good corrosion protection.
- **Integrated wall-mounting** - For simpler installation.
- **Slip connections for bonding of Ø50 mm pipes** - For simple pipe installation.
- **Two sizes 40 and 75 kW** - For swimming pools of up to 300 m³.
- **Connects to boiler, heat pump, solar panel system or other heat source** - Suits all installations.

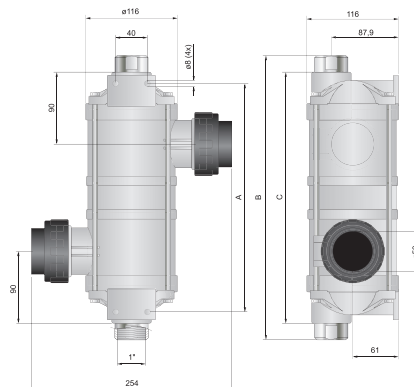
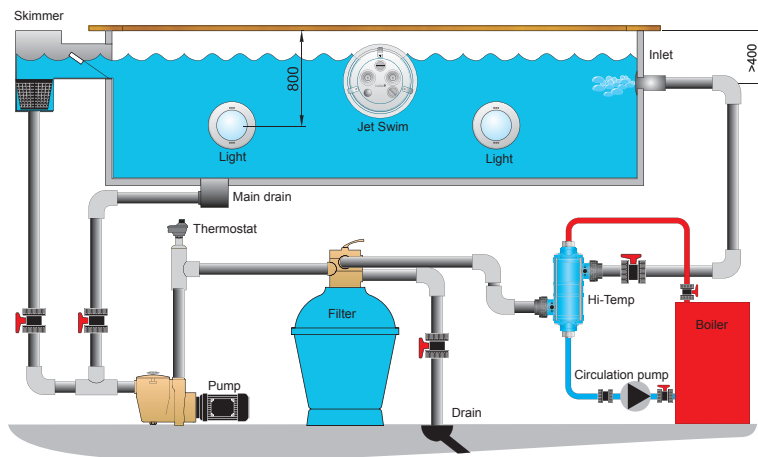

Dimensions

Item no.	A	B	C
11312	359	317	277
11314	534	492	452

The maximum pressure for the secondary circuit (pool water) is 4 bar and for the primary circuit (hot water) 5 bar.

Technical data

Item no.	Model	Capacity		Primary, hot water		Secondary, pool water	
		kW	kBtu/h	l/min	press. drop H(m)	l/min	press. drop H(m)
11312	HT 40	40	135	34	2,4	300	0,5
11314	HT 75	75	260	43	6,0	300	1,0

Capacity at 60° temperature difference